

TOFTUN4

TOYOTA

Front suspension package
Ensemble pour suspension avant
Ensemble para suspensión de delantero

INSTALLATION INSTRUCTIONS

- Raise vehicle allowing the axle to hang freely.
- Where four bump stops exist, remove rear bumpstop.
- Mount Timbren assembly using existing holes & Timbren supplied fasteners.
- Lower vehicle.

NOTES:

When removing OEM fasteners, use penetrating fluid.
If OEM nut is damaged use Timbren supplied fastener #3

INSTRUCTIONS DE MONTAGE

- Soulever le véhicule de sorte que l'essieu soit dégagé.
- Enlever la butée d'essieu arrière là où il y en a quatre.
- Monter l'assemblage Timbren en utilisant les trous existants et la boulonnerie fournie avec l'assemblage Timbren.
- Redescendre le véhicule.

REMARQUES:

Utiliser un fluide pénétrant, au moment de retirer la boulonnerie du fabricant d'équipement.
Si l'écrou d'origine est endommagé utiliser l'attache no. 3.

INSTRUCCIONES DE INSTALACIÓN

- Levante el vehículo dejando que los ejes cuelguen libremente.
- Retirar el tope de el eje trasero adonde hay cuatro de ellos.
- Monte la unidad Timbren utilizando los orificios existentes y los elementos de sujeción Timbren provistos.
- Baje el vehículo.

NOTAS:

Al remover los elementos de sujeción del fabricante original de equipo, utilice fluido penetrante.
Si la tuerca de origen se daña utilizar los elementos de sujeción #3

Ref. = Reference = No. de référence = Núm. de referencia
Part = Part #. = No. de pièce = Núm. de pieza
Qty. = Quantity = Quantité = Cantidad

KIT PRE-ASSEMBLED

Ref	Part	Qty
1	A00180-75T00	2
2	F13536-853	2
3	F31051-450	2

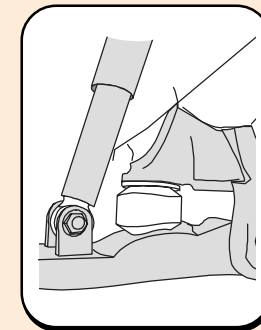
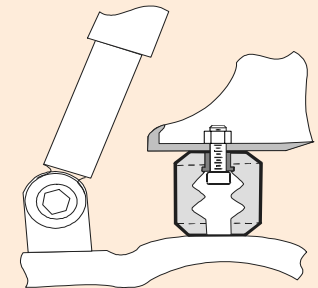
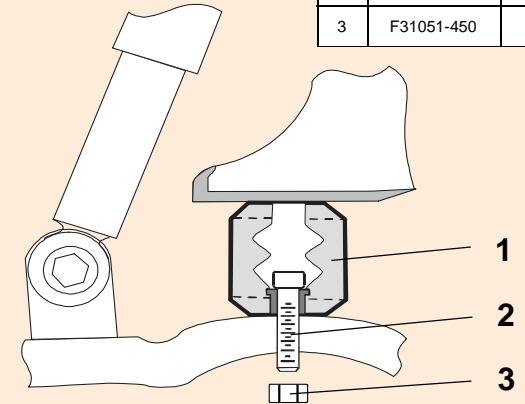

Do not exceed vehicle manufacturer's recommended axle weight rating. Check for AEON® interference with vehicle components - Under load AEON® will "expand" in diameter.

Ne pas dépasser le poids nominal sur l'essieu recommandé par le fabricant du véhicule. Vérifier que le ressort AEON® n'a pas d'incidence sur d'autres pièces du véhicule - Le ressort AEON® augmentera son diamètre avec la charge.

No exceda la carga nominal en el eje recomendada por el fabricante del vehículo. Compruebe que no haya interferencia entre el resorte AEON® y los otros componentes del vehículo. Bajo carga, el resorte AEON® se ampliará en diámetro.

TOFTUN4



TOFTUN4

TIMBREN INDUSTRIES INC.

www.timbren.com

PART NUMBER	DESCRIPTION	QTY	LOCATION
F31051-450	NYLOCK LOCKNUT M10 x 1.25 GR 8.0 Z	2	I1E
F13536-853	SHCS M10 x 30 x 1.25 F/T GR 8.8 B	2	J3D

A00180-75T00	Hollow Rubber Spring	2	C3A
--------------	----------------------	---	-----

B90264-CF	MINI FRONT BOX - 7 x 5.25 x 4.75	1	A--D
B10000	8" x 12" BUBBLE FOR KITS	1	
B00029-010	BARCODE LABEL FOR KIT	1	

ASSEMBLY NOTES:

PRE-ASSEMBLED KIT
USE LOCTITE

NOTE: M10 FINE THREAD HDWE

Issued: 4/27/2011

Clearance Instructions:

Rear SES Kits for Pick-Ups and Vans should have a 1/2" to 1-1/2" gap between the rubber spring and contact point when empty.

A partial load, or vehicle accessories will reduce or eliminate the gap.

Front SES kits are usually in full contact.

Medium and Heavy-Duty Trucks, Trailers and Motorhomes will be in constant contact, and have no gap.

Lifetime Warranty:

Timbren SES Kits are warranted against defects in material and workmanship, under normal use and service, for the life of the vehicle on which the kit was originally installed. The warranty is not transferable and proof of purchase is required. The warranty is limited to the replacement of the failed part.

TIMBREN will not be responsible for any labour or freight charges involved in the replacement of any product. TIMBREN shall be entitled to make its own inspection to determine the validity of the claim. TIMBREN shall not be liable nor warranty the product in the event of alteration, misuse, overload, negligence or damage caused by others.

If ride or performance of our product is unsatisfactory in any way, please call: 1-800-263-3113 or email sales@timbren.com